

Roller Blind System

Optima 250D



System Types Optima 250D



Advantages

Bracket Colours

Integrated Bracket/Mechanism colours for Single & Double Roller with support profile



Bottom Rail

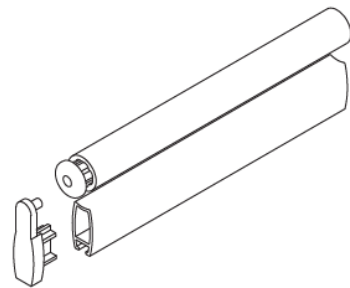

Technical Specifications Optima 250D

Small light gaps

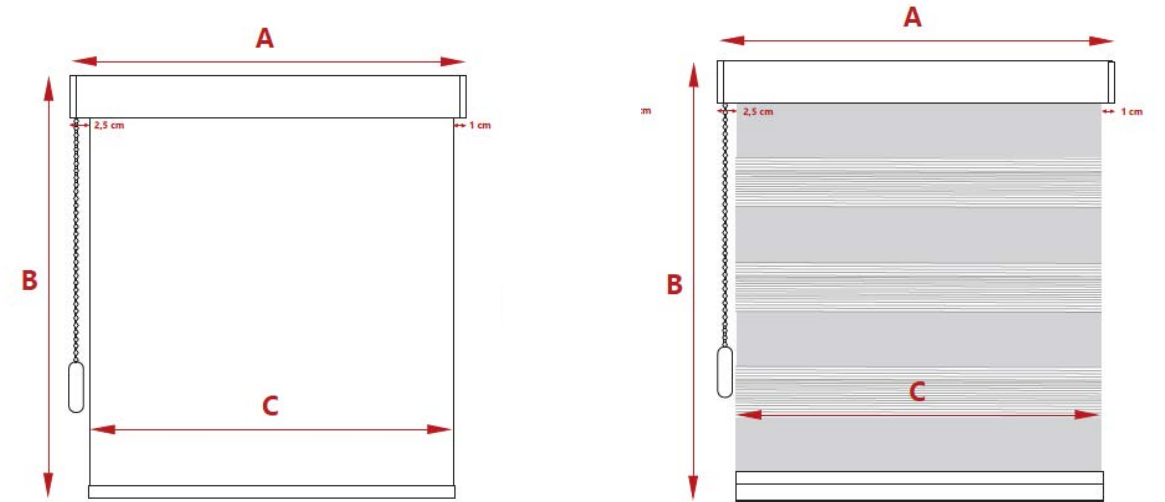

Single fabric roller:

- A** - Single roller overall width from end to end (with end caps)
- B** - Total height of single roller from end to end (with valance and bottom bar)
- C** - Fabric width

Double fabric roller:

- A** - Double roller overall width end to end (with end caps)
- B** - Double roller overall height from end to end (with valance and bottom bar) when the shade is in the closed position
- C** - Fabric width

Planning Information Optima 250D

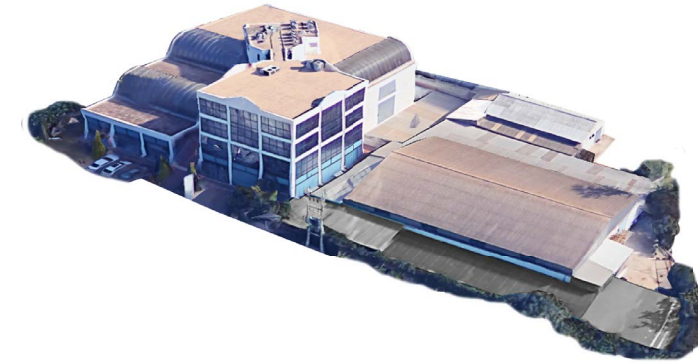
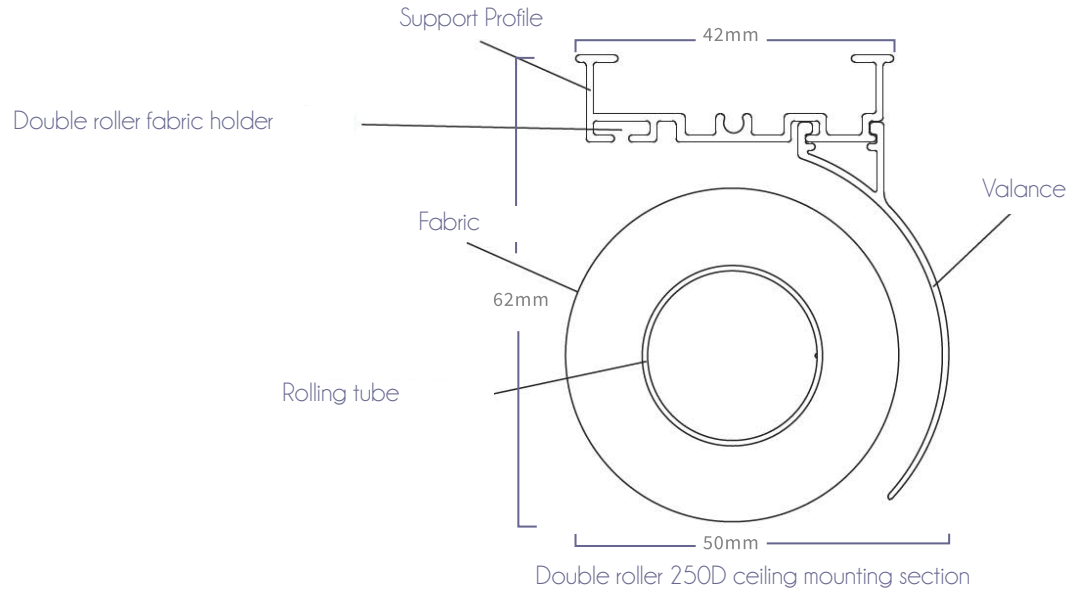

Company Profile

Optima blinds are supplied exclusively by N. Assimakopoulos SA being the largest manufacturing company in natural light control system applications while exceeding 50 years of specialization and involving staff/partners of 40 people. In privately owned facilities of 5,000 sq.m. in Elliniko the company sells its products with vertical organization that optimizes cost, quality and delivery time through:

- Import or domestic production of A & B materials.
- Processing and assembly using hydraulic/pneumatic forming machines for cutting/drilling aluminum sheets or profiles, laser/ultrasonic plotters and machine tools of own machine shop down to finished, aesthetically and functionally tested final systems.
- Study and project management by specialized engineers/designers and implementers of proven know-how who offer long lasting reliable solutions to special requirements.
- Installation by specialized crews trained and supervised by engineers with over 25 years of experience in the organization of construction sites and technical applications.
- After-sales support (maintenance, repair, spare parts).
- ISO 9001/14001 certified customer-order/environmental management procedures respectively.

Maximum Dimensions (Quick reference only, depending on type of fabric)			
Maximum Width (m)	Maximum Height (m)	Maximum Surface (m ²)	Fabric
1.95	3	5.46	Plain
1.45	3	4.06	Blackout
1.25	3	3.5	Screen

Head Office - Factory:
2 Rizountos Str. & Thrakis Str. 16777,
Elliniko, Athens GR
(+30) 210 9600 960
(fax) 210 9607 429
info@assimakopoulos.gr

Optima Elements Voula:
58 Vouliagmenis Ave.,
16673, Greece
210 9680539,
210 9680739
voula@optimaelements.gr

Optima Elements Marousi:
Marousi - 139 Kifisias Ave.
& Marathonodromou,
15124, Greece
210 8054190, 210 8054580
marousi@optimaelements.gr