



ASSIMAKOPOULOS

Roller Blind System

Optima 800



OPTIMA
performance shades

System Types Optima 800

Standard Brackets
(800 A)

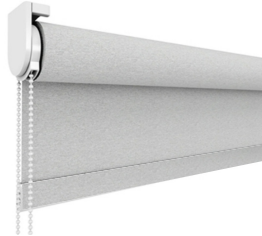

Options

Square Cassette
(CAS800 SQUARE)



Bracket colors



Cassette Colors

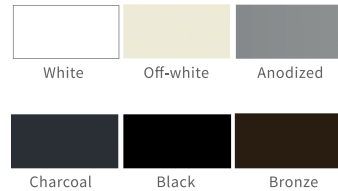

Technical Specifications Optima 800

Advantages

- Modular construction: upgrade from basic to fully equipped using minimum additional components
- Wide variety of finishes and colors
- Easy assembly, installation and use

Chain

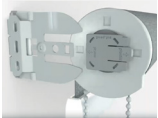

Motor

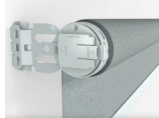

Components Material

All visible parts are available in ABS plastic as well as metal. ABS components are available in six basic colors, metal components in six different finishes. For optimal user experience, the chain mechanism in the metal system is the same as that of the ABS plastic system and has been designed for smooth operation.

Bracket and Profile Properties

	Bracket	Profile
Thickness	1,5 mm	1,5 mm
Material	Steel	EN - AW - 6060 - T5
Color	6 colors ABS 6 metallic colors	6 aluminum colors

Chain (transmission 1:1) Motor (wired or wireless)



Small light gaps

(fabric to outer brackets)

Tube

- Material: EN-AW-6060 T6 (Extruded aluminum)
- Finish: Mill

Brackets

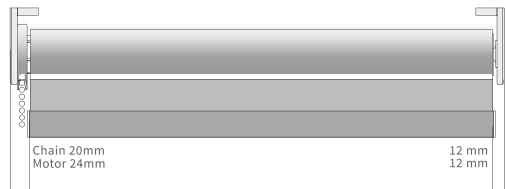

OPTIMA
performance shades

Planning Information Optima 800

Brackets

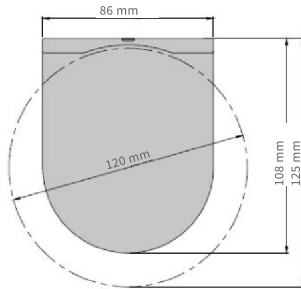

Closed Square Cassette

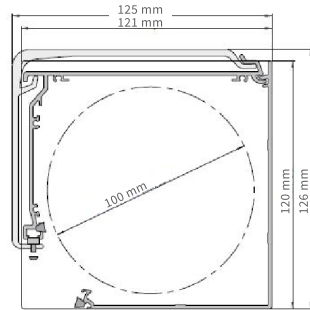

Aluminum side guides

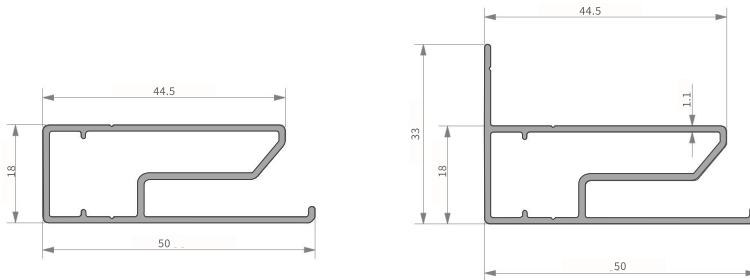

System of aluminum side guides

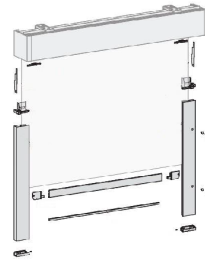

Wire side guides

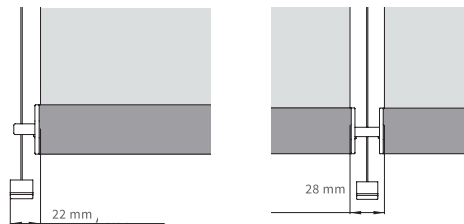

Wire guided system

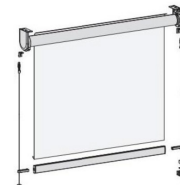

Planning Information Optima 800

Bottom Rails

Aluminum Flat (fabric dressed)
15x30mm

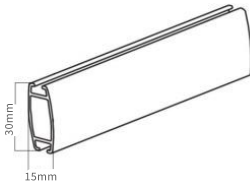

Aluminum Round
(fabric dressed)
diameter 23mm

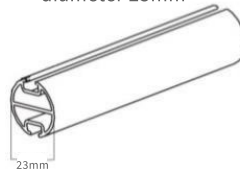

Aluminum Flat heavy duty
35x15mm

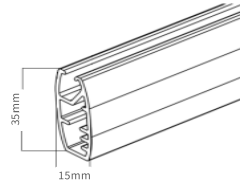

Maximum Dimensions

(Quick reference only, depending on type of fabric)

Maximum Width (m)	Maximum Height (m)	Maximum Surface (m ²)	Fabric
4,45	5	12,46	Plain
4,2	5	11,76	Blackout
4,15	5	11,62	Screen

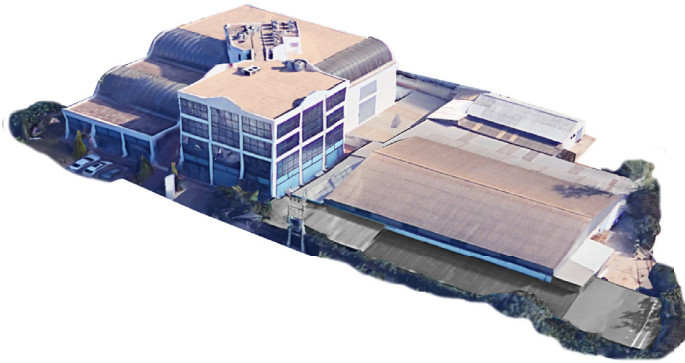

Company Profile

Optima blinds are supplied exclusively by N. Assimakopoulos SA being the largest manufacturing company in natural light control system applications while exceeding 50 years of specialization and involving staff/partners of 40 people.

In privately owned facilities of 5,000 sq.m. in Elliniko the company sells its products with vertical organization that optimizes cost, quality and delivery time through:

- Import or domestic production of A & B materials.
- Processing and assembly using hydraulic/pneumatic forming machines for cutting/drilling aluminum sheets or profiles, laser/ultrasonic plotters and machine tools of own machine shop down to finished, aesthetically and functionally tested final systems.
- Study and project management by specialized engineers/designers and implementers of proven know-how who offer long lasting reliable solutions to special requirements.
- Installation by specialized crews trained and supervised by engineers with over 25 years of experience in the organization of construction sites and technical applications.
- After-sales support (maintenance, repair, spare parts).
- ISO 9001/14001 certified customer-order/environmental management procedures respectively.

Head Office - Factory:

2 Rizountos Str. & Thrakis Str. 16777,
Elliniko, Athens GR
(+30) 210 9600 960
(fax) 210 9607 429
info@assimakopoulos.gr

Optima Elements Voula:

58 Vouliagmenis Ave.,
16673, Greece
210 9680539,
210 9680739
voula@optimaelements.gr

Optima Elements Marousi:

Marousi - 139 Kifisias Ave.
& Marathonodromou,
15124, Greece
210 8054190, 210 8054580
marousi@optimaelements.gr